

AC700



POWER
YOUR
FUTURE

700kVA / 560kW
POWERED by CUMMINS

DIESEL GENERATING SET 400/230 V - 50 Hz - 3 Phase

| MODEL | | | AC700 |
|------------------|---------|-----|-------|
| Power Pf. 0.8 | Standby | kVA | 700 |
| | | kW | 560 |
| | Prime | kVA | 638 |
| | | kW | 510.4 |

Standby: Continuous running at variable load for duration of an emergency. No overload is permitted on these ratings. In accordance with ISO 3046.
Prime: Continuous running at variable load for unlimited periods with 10% overload available for 1 hour in any 12 hour period. In accordance with ISO 8528,ISO 3046.

- ✓ High quality, reliable and complete power unit
- ✓ Compact design
- ✓ Easy start and maintenance possibility
- ✓ Every generating set is subject to a comprehensive test program which includes full load testing, checking and provision of all control and safety shut down functions testing
- ✓ Fully engineered with a wide range of options and accessories: Canopy, sound proof canopy and on-road trailer



Manufacturer reserves the right to make changes in model, technical specifications, color, equipment and accessories without prior notice.

ENGINE

CUMMINS

| CUMMINS | | |
|----------------------------------|---------------------|----------------------------|
| Model | | VTA28G5 |
| Engine Power Output at rated rpm | kWm | 615 |
| | HP | 825 |
| Aspiration and Cooling | | Turbocharged & Aftercooled |
| Total Displacement | Litre | 28 |
| No. of Cylinders and Build | | 12 V |
| Engine Speed | rpm | 1500 |
| Bore and Stroke | mmxmm | 140x152 |
| Compression Ratio | | 13.1:1 |
| Governor | | Electronic |
| Fuel Consumption at full load | L/hr | 140 |
| Fuel Tank Capacity | Litre | 1000 |
| Oil Capacity | Litre | 83 |
| Coolant Capacity | Litre | 146 |
| Radiator Cooling Air | m ³ /min | 864 |
| Air Intake – Engine | m ³ /min | 52.68 |
| Exhaust Gas Flow | m ³ /min | 122.88 |

- ✓ Heavy duty Cummins diesel engine
- ✓ Four stroke, water cooled, turbocharged & aftercooled
- ✓ Direct injection fuel system
- ✓ Electronic Governor system
- ✓ 12/24 V D.C. starter and charge alternator
- ✓ Replaceable fuel filter, oil filter and dry element air filter
- ✓ Cooling radiator and fan
- ✓ Starter battery (with lead acid) including Rack and Cables
- ✓ Flexible fuel connection hoses and manual oil sump drain valve
- ✓ Industrial capacity exhaust silencer and steel bellows
- ✓ Jacket water heater(at automatic models)
- ✓ Operation manuals and circuit diagram documents

ALTERNATOR

| | |
|---------------------------------------|--|
| Design | Brushless single bearing, revolving field |
| Stator | 2/3 pitch |
| Rotor | Single bearing, flexible disc |
| Insulation System | Class H |
| Standard Temperature Rise | 125 - 163°C Continuous |
| Exciter Type | Self Excited |
| Phase Rotation | A (U), B (V), C (W) |
| Alternator Cooling | Direct drive centrifugal blower fan |
| AC Waveform Total Harmonic Distortion | No load < 1.5%. Non distorting balanced linear load < 5% |
| Telephone Influence Factor (TIF) | <50 per NEMA MG1-22.43 |
| Telephone Harmonic Factor (THF) | <2% |

- ✓ Brushless, single bearing system, flexible disc, 4 poles
- ✓ Insulation class H
- ✓ Standard degree of protection IP21 (*IP22/IP23 is available.)
- ✓ Self-exciting and self-regulating
- ✓ Impregnation with tropicalised epoxy varnish
- ✓ Solid state Automatic Voltage Regulator
- ✓ Stator winding with 2/3 pitch for improved harmonics

CONTROL SYSTEM

Control supervision and protection panel is mounted on the genset base frame. The control panel is equipped as follows:

1. Auto Mains Failure Control Panel

Panel equipments:

- ✓ Control with AMF module
- ✓ Static battery charger
- ✓ Emergency stop push button

a) Generating set control module DSE 7320 features:

- ✓ The module is used to monitor a mains supply and starts and stops a standby generating set
- ✓ Micro-processor based design
- ✓ Automatic control of mains and generator contactors
- ✓ Monitors engine performance and AC power output
- ✓ LED alarm indication
- ✓ Front panel configuration of timers and alarm trip points
- ✓ Easy push button control
STOP/RESET - MANUAL - TEST - AUTO - MUTE ALARM - START

b) Metering via LED display:

- ✓ Generator Volts (L-L / L-N)
- ✓ Engine oil pressure (PSI-Bar)
- ✓ Generator Ampere (L1,L2,L3)
- ✓ Engine temperature (° C & ° F)
- ✓ Generator Frequency (Hz)
- ✓ Plant battery volts
- ✓ Engine hours run
- ✓ Mains Volts (Ph-Ph/Ph-N)
- ✓ Generator kVA, kWh
- ✓ Generator kW as % of rated kW setting
- ✓ Generator Cos (σ)

2. Power Outlet Terminal Board Mounted on the Genset Base Frame



DSE 7320

c) Alarms:

- ✓ Over and Under Speed
- ✓ Low and High Battery Volt.
- ✓ Start and Stop Failure
- ✓ Charge fail
- ✓ Over Current
- ✓ Under / Over Generator Voltage
- ✓ Low Oil Pressure
- ✓ Emergency stop
- ✓ High engine temperature
- ✓ kW overload
- ✓ Unbalanced load
- ✓ Independent earth fault trip

d) LED indications

Four configurable LED's like:

- ✓ Mains available
- ✓ Generator available
- ✓ Mains on load
- ✓ Generator on load

OPTIONAL EQUIPMENTS

Diesel Engine

- ✓ Oil heater

Alternator

- ✓ 3/4 Pole Output Circuit Breaker
- ✓ Anti-condensation Heater

Panel

- ✓ Charge ammeter
- ✓ Transfer Switch 3 Pole
- ✓ Transfer Switch 4 Pole
- ✓ Earth Fault ,single set

Accessories

- ✓ Bulk fuel tank
- ✓ Automatic filling system
- ✓ Fuel-water separator filter
- ✓ Low fuel level alarm
- ✓ Residential silencer
- ✓ Enclosure or sound proof canopy
- ✓ Trailer
- ✓ Manual oil drain pump
- ✓ Tool kit for maintenance

CHASSIS

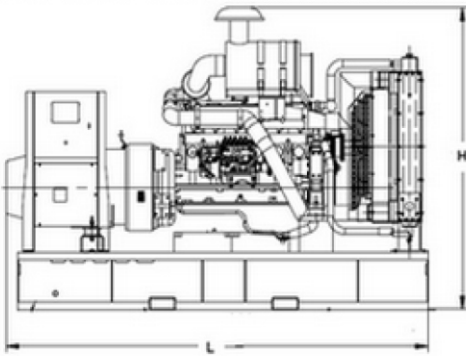

- ✓ The complete gen-set is mounted as whole on a heavy-duty fabricated, steel base frame
- ✓ Anti-vibration pads are fixed between the engine/ alternator feet and the base frame
- ✓ Base frame design incorporates an integral fuel tank (Up to 1000 kVA)
- ✓ The generating set can be lifted or carefully pushed / pulled by the base frame
- ✓ Dial type fuel gauge and drain plug on the fuel tank
- ✓ Forklift pockets within base frame (up to 500kVA)

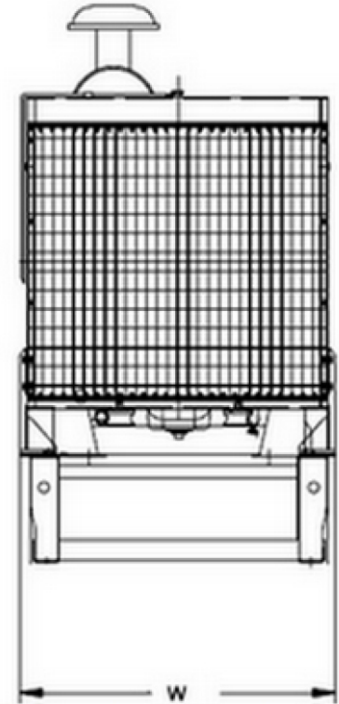

DIMENSIONS

OPEN TYPE

| | | |
|--------------------|----|----------------|
| DIMENSIONS (LxWxH) | mm | 4100x1800x2158 |
| DRY WEIGHT | kg | 5660 |

SOUND ATTENUATED TYPE

| | | |
|--------------------|----|----------------|
| DIMENSIONS (LxWxH) | mm | 5313x1606x2658 |
| DRY WEIGHT | kg | 7500 |

CANOPY

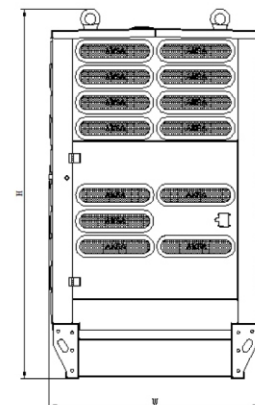
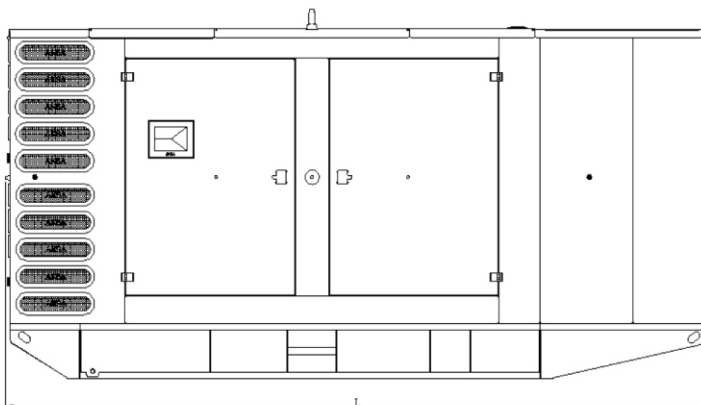

- ✓ All canopy parts are designed with modular principles
- ✓ Without welding assembly
- ✓ Doors on each side
- ✓ All metal canopy parts are painted by electrostatic polyester powder paint
- ✓ Exhaust silencer is protected against environment influences
- ✓ Thermally insulated engine exhaust system
- ✓ Emergency stop push button is installed outside of the canopy
- ✓ Easy lifting and moving
- ✓ Easy maintenance and operation

